



TOOL PRESSETTER
rock solid measurement



TOOL PRESSETTER
rock solid measurement



TECHNICAL FEATURES

- Measuring range: diameter max 400 mm (radius 200 mm); height max 600 mm
- Machine structure in stainless steel offering high mechanical and long life, floor mounted with self-levelling supports in non-deformable steel
- Base and column made of ground granite: linearity max error 2 µm/Mt certification with Taylor Hobson res.1 µm/Mt electronic millesimal level
- ISO/BT/HSK/VDI etc. Interchangeable rotating spindle-holder (to be specified) max run-out error < 2 µm
- Double vault arc prismatic slideways: n°2 X axis slideways, n°1 Z axis slideway
- Double re-circulating ball bearing slides, lubricated for life (3) (preloading slides/slideways: P/H class)
- Universal mechanical tool clamping managed via software
- Control via software with sensor of empty for the exact position between the tool-holder axis and the machine spindle axis, no error of concentricity
- Pneumatic-mechanic braking of the spindle-holder rotation with radial compensation of the clamping force: no axis angular run error
- Constant load Archimedean spiral spring (as opposed to a mass counter-balance system)
- Vision-system for tool measuring and cutting inspection consisting of:
 - C-MOS sensor - Framed image area 6,4 x 6,4 mm
 - Magnifications about 30X
 - Telecentric lens
 - Doublet lenses at low F/Number in order to eliminate the error of the clearness circle
 - Red light episcopic leds illuminator with ring lens, red light diasopic led puntiform illuminator
- Machine operator interface through:
 - TFT 15" colour Touch Screen
 - Intel Atom D.C. fanless motherboard
 - UBUNTU LINUX operating system
 - Data storage on solid state disk SSD
 - X and Z axes block management with control maximum speed of translation 2mm/sec
 - N°3 USB ports and N°1 LAN
- Standard software:
 - CNC machine origin management and adapters
 - Tool list creation and/or single tool
 - Automatic change of CNC machine origin allocation
 - Td SIX (Tool Data SIX) to manage:
 - tools set and Post Processor universal generator
 - magnetic chip code-holders (Balluff for example, hardware not included)
 - printable tool set report
 - theoretical measurements and tolerances management
- ELBO CONTROLLI Linear Transducers in optical glass type SLIDE 371 certified HP laser:
 - Axes resolution: X= 1 µm, Z= 1 µm
- Anti-dust cover provided for when not in use
- Overall dimensions: Length = 1240 mm, Height = 1840 mm, Depth = 558 mm
- Net weight: 185 Kg

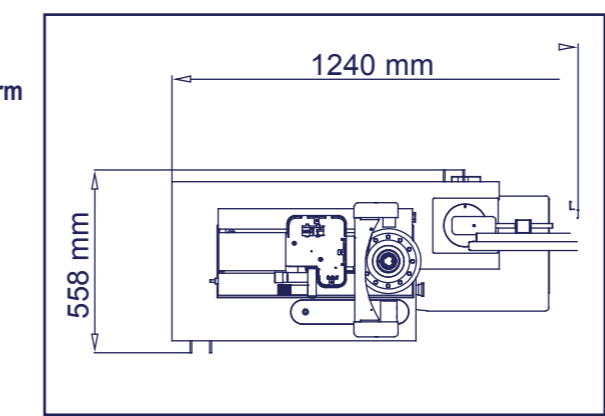
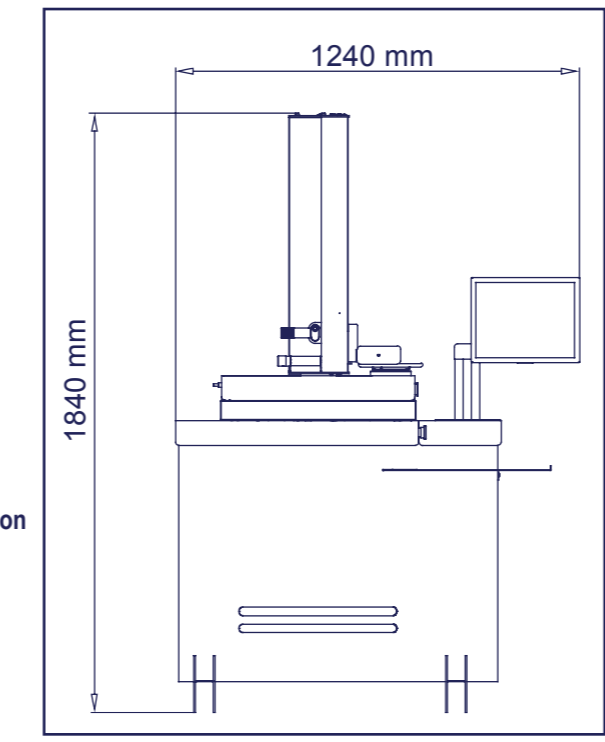

Distributed by

20821 MEDA (MB) - Italy - Via San Giorgio, 21
T. +39 0362 342745 - **F.** +39 0362 342741
 www.elbocontrolli.com - info@elbocontrolli.it





Interchangeable rotating spindle with mechanical rotation brake.
Two preloaded ball cages allow a concentricity accuracy within 2 µm.



Camera system for measuring with punctiform illuminator and inspection with ring illuminator.
C-MOS sensor.
Telecentric optic system with low F/Number.

Td SIX (Tool Data SIX)



Td SIX is a new software function developed by Elbo Controlli, used to acquire tool's measurements, to input them into the tooling tables and create a file including tools offsets.



Micrometric registration of X and Z axes by means of two wheels which are essential for the collimation of the measure with a fixed target function.



Large 15" touch screen for the best visualization of the tools and simple management functions to operate the measuring machine.



The data are elaborated and post-processed by the software. There are more than 50 post-processor format for the most common numerical controls available on machine tool market.



Manual axes movement. Axis unclamping by means of a single pneumatic control system.



New electronic control: a powerful fanless PC with Linux operating system for the integrated management of the functions of measurement / inspection tools, machine origins and toolsets. Ease of use thanks to the integrated touch screen.

X and Z axes block management with control maximum speed of translation 2mm/sec.



Base and column made of ground granite. The thermal inertia of this material allows the machine to be placed directly in the workshop. Mechanical elements manufactured from stainless steel.



Inspection function for accurate control of the tool status. Possibility to increase or decrease the brightness for a better visibility. 4 different coloured filters to highlight tool damages.

MACHINE 1 TOOLSET 1
Mon Oct 27 2014

T	Code	x	xTh	z	zTh	A	R
1	MILL D.10	9.918	10 ^{+0,00} _{-0,10}	166.46	166.5 ^{+0,05} _{-0,05}		
2	SHELL MILL	0	0	105.594	105.6	45	
3	BORING BAR	19.013	19 ^{+0,018} _{-0,01}	227.51	0		0.02

It's possible to generate and / or print a report with the theoretical values, tolerances and measurements of the selected tool table.

MACHINE 1 TOOLSET 1
Mon Oct 27 2014

T	Code	x	xTh	z	zTh	A	R
1	MILL D.10	9.918	10 ^{+0,00} _{-0,10}	166.46	166.5 ^{+0,05} _{-0,05}		
2	SHELL MILL	0	0	105.594	105.6	45	
3	BORING BAR	19.013	19 ^{+0,018} _{-0,01}	227.51	0		0.02